

Implementing IAS39

Chris Clegg

Head of Balance Sheet Management

ALMA Conference - January 2005

Feedback

ALMA Timeline

- May 2001 - Peter Torrente on FAS133
- July 2001 - IAS39 Working Group
- Jun 2002 - ALMA / AFGAP Conference
- Feb 2003 - European Teleconference
- Nov 2003 - Response to Amendments
- Dec 2003 - Banker Article
- Sep 2004! - EU Carve-out
- Jan 2005 - All done!

abbey

Good News

Uniform approach
Fair values
Macro hedging
Cashflow hedging
Embedded derivatives

Bad News

Applied inconsistently
Exclusions
No portfolio hedging
Cashflow hedging
Mixed interpretation
Corporate focus
Fixed Rate Good
Floating Rate Bad

abbey

Good News

Uniform approach
Fair values
Macro hedging
Cashflow hedging
Embedded derivatives

Bad News

Applied inconsistency
Exclusions
No portfolio hedging
Cashflow hedging
Mixed interpretation
Corporate focus
Fixed Rate Good
Floating Rate Bad

Opportunity for change!

abbey

Abbey approach

Overarching IAS project

Hedging workstream

Wholesale - Mostly MtM

Issuance - Micro FV or FV Option - **BUT.....**

Banking - “Hedging Business Model”

Other

Securitisation

Capped Mortgages

Operating Leases

abbey

Hedging Model (2003 - ?)

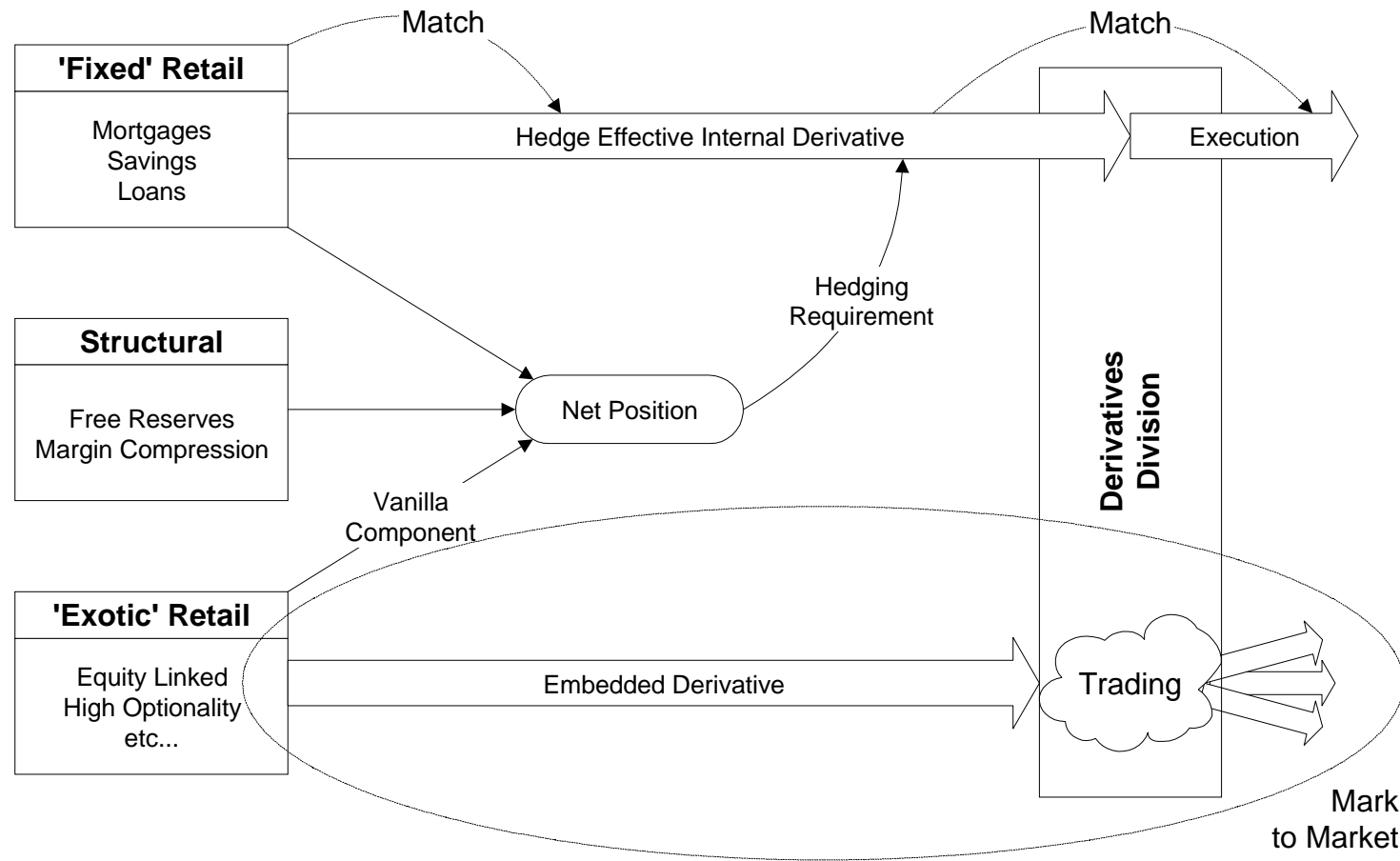

abbey

System Architecture

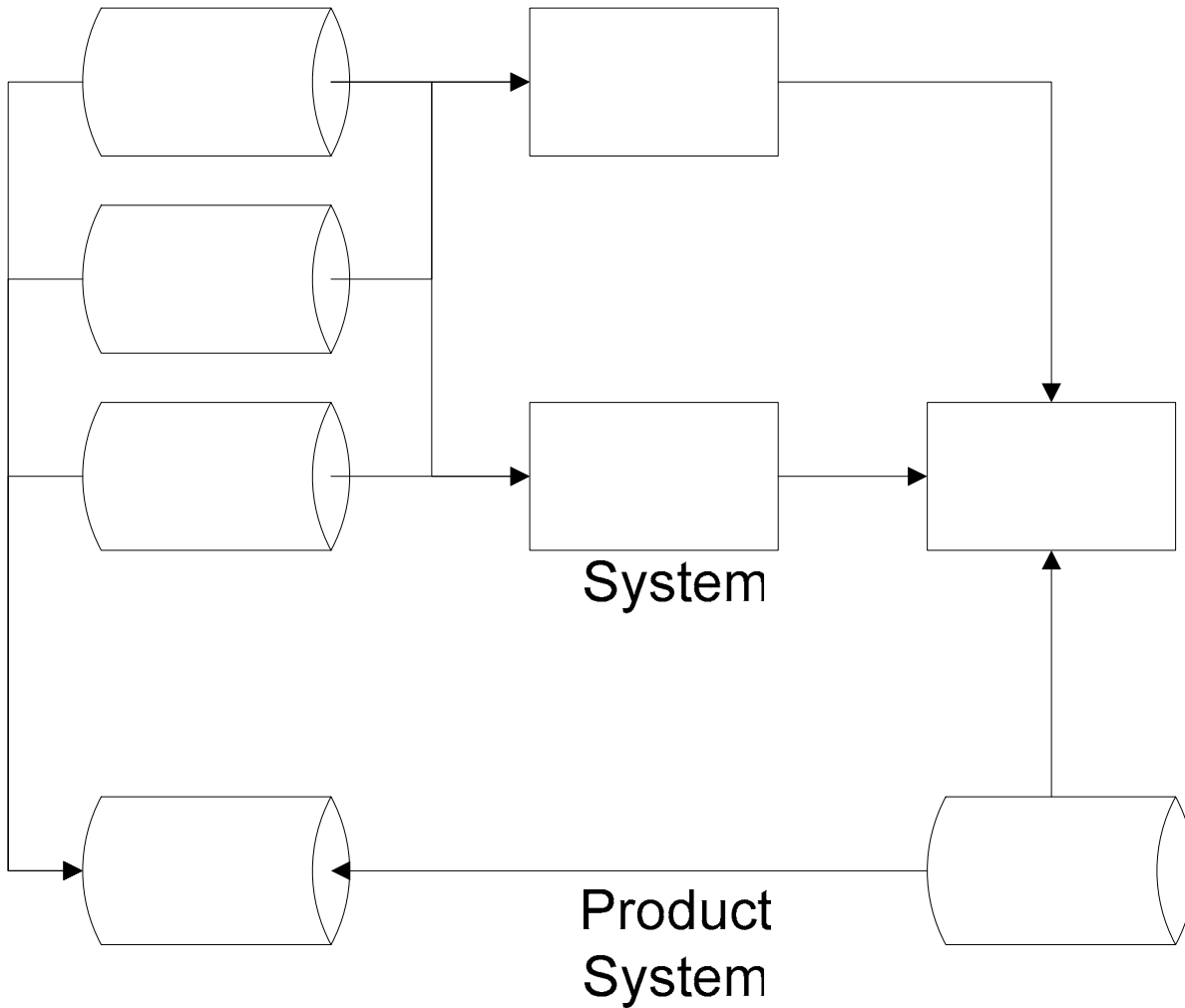

Risk
System

abbey

System Architecture

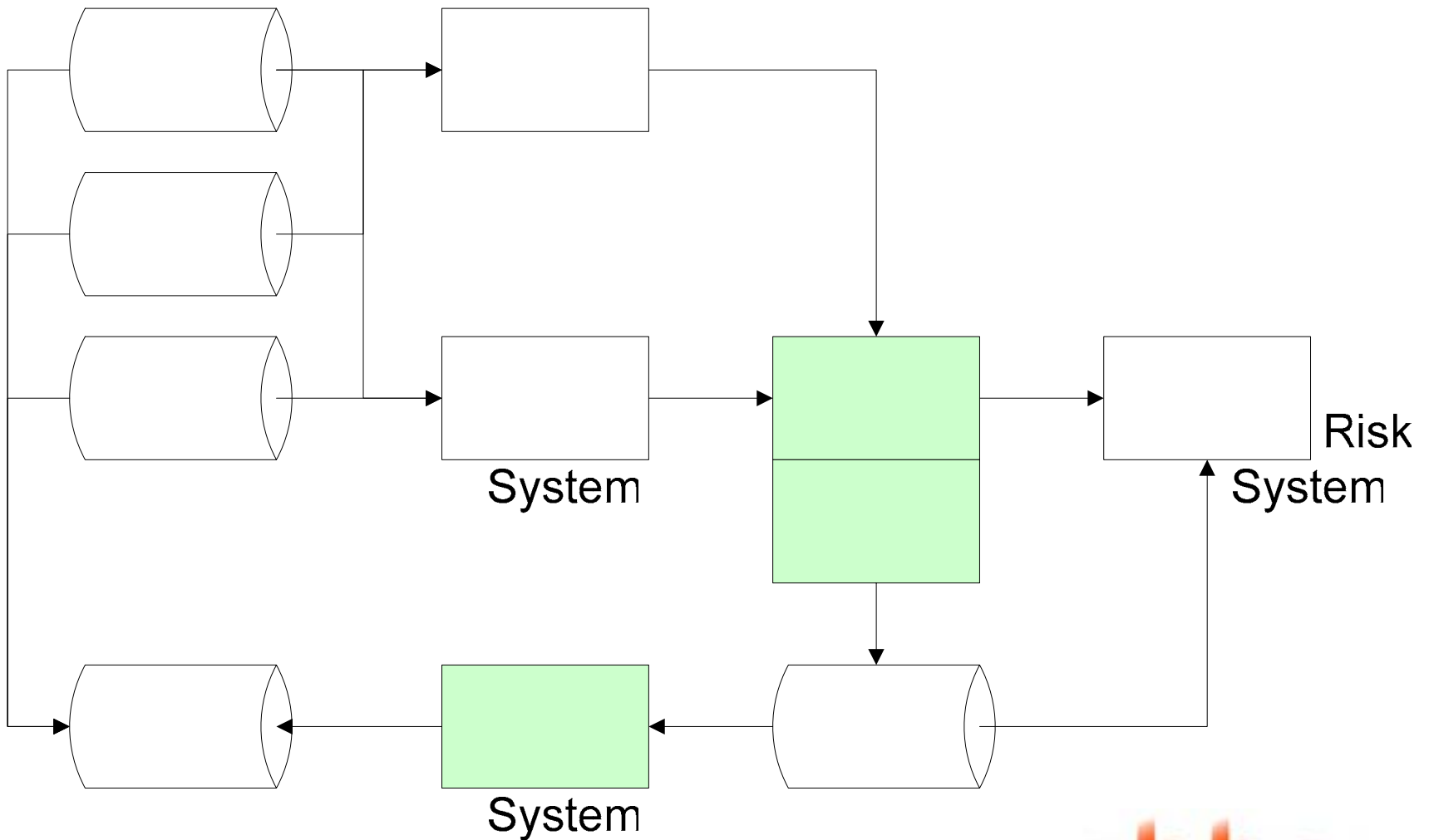

abbey

And so the fun begins!

x Micro Fair Value

- Bottom Slicing? - Rejected in amendment
- “Creative” Top Slicing - Technical reject
- Poor match with existing hedge portfolio

✓ Macro Fair Value

- Enabled in amendment
- Portfolio effects smooth noise
- Good match with existing hedge portfolio
- Dangling legs!

abbey

EU Carve-out : T - 63¹/₂ !

No more Fair Value Option for liabilities

“Exotic” savings accounts

Complex MTNs

Bifurcate back to FRN, (where possible)

Product Development issues

Use the right words!

Major system issues

Likely to be reversed

Tactical or Strategic solution?

abbey

What now?

First reporting point

- Hedge effectiveness

- Update / Posting engine

EU Carve in/out?

Tactical to Strategic solutions

Ongoing development

abbey